



Dust Control and Loading Systems Inc

Leaders in Innovative Bulk Loading Systems Design

Slide Gate Valve

SLIDE GATE VALVE

DCL's Model SV Slide Gate Valves are designed to shut off product flow from outlets of storage bins, silos, conveyors, and other discharge points handling dry bulk materials.

These rugged heavy duty slide gate valves are available in standard sizes ranging from 6 inches to 36 inches square. Sizes larger than 36 inches, rectangular, and special configurations including dual opposing blade and dewatering designs are available on a custom build basis.

A choice of construction materials allow handling of all types of products and applications; fine, granular, lumpy, abrasive, corrosive, or sanitary.

FEATURES

The valve frame is constructed from heavy duty 3/16 inch steel with a hardened blanchard ground blade which rides on cam rollers or solid guides. Actuation of Slide Gate Valves can be accomplished in many ways; pneumatically for fast action, hydraulically for power, electrically for precise positioning, and manually for maintenance and flow control.



Blade seals are selected according to the material being handled and are available to suit any application. A molded urethane inlet liner provides an ideal blade seal when handling granular products. Additional frame seals are available and should be used when handling fine dusty material. Adjustable seals are also available to virtually eliminate the need for seal replacement. These seals are adjusted from the outside of the valve frame, which makes it unique to the industry.

All SV Slide Gate Valves are equipped with a dust tight transition unless mounted directly above another valve. This transition is recommended when handling fine dusty material.

ULTIMATE FLOW CONTROL PACKAGE

The ultimate flow control package consists of a manually actuated and a powered Slide Gate Valve. With this configuration you can preset product flow with the manual valve and use the powered valve as a shut off.

In the case of product maintenance or equipment failure you can manually shut off the flow valve and service any equipment beneath it.

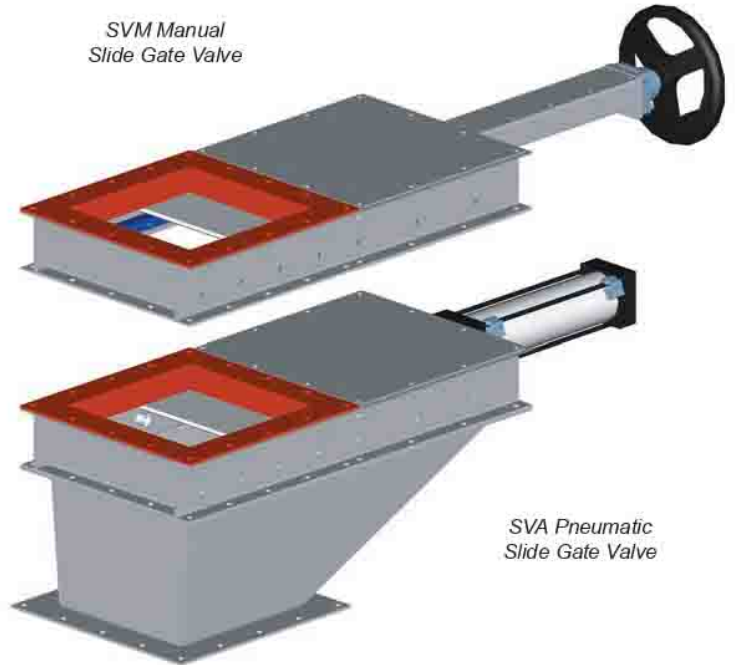

SVM Manual Slide Gate Valve

SVA Pneumatic Slide Gate Valve

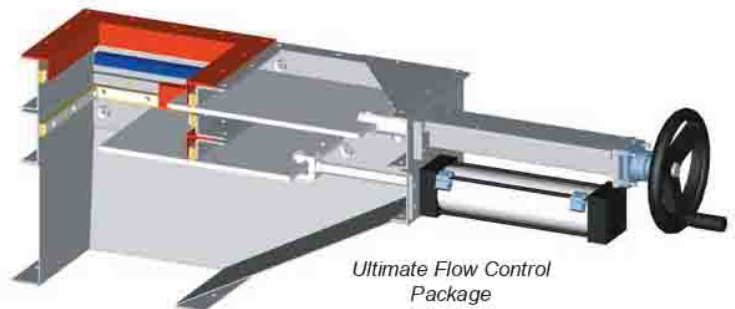

Ultimate Flow Control Package

08660 Ance Road
Charlevoix, Michigan 49720

Dust Control and Loading Systems Inc
www.dclinc.com or sales@dclinc.com

Tele: 800-748-0563
231-547-5600



Dust Control and Loading Systems Inc

Leaders in Innovative Bulk Loading Systems Design

Curved Blade Valve

CURVED BLADE VALVE

DCL's Model Curved Blade Valves are designed to cut off product flow from outlets of storage bins, silos, conveyors, gravity flow chutes and other discharge points handling dry bulk materials.

These rugged heavy duty curved blade valves are available in standard sizes ranging from 6 inches to 36 inches square. Sizes larger than 36 inches, rectangular, and special configurations including hardened liners are available on a custom build basis.

A choice of construction materials allow handling of all types of products; fine, granular, abrasive, corrosive, and sanitary applications.

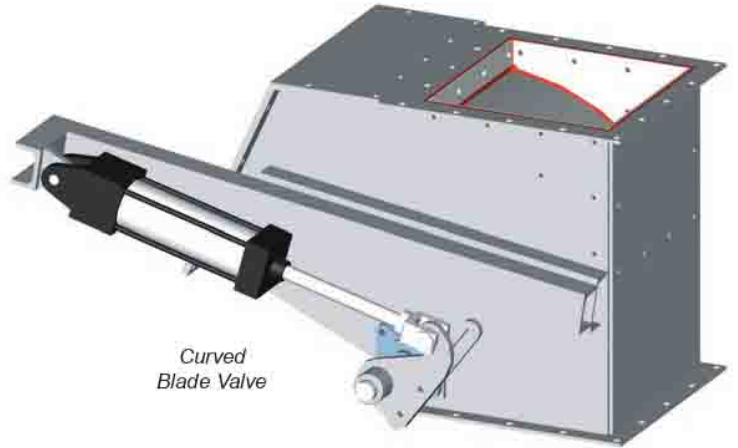

Curved
Blade Valve



FEATURES

The Curved Blade Valves are fast acting, tight sealing, and very effective for regulating flow rates. The curved blade valve should only be used when handling fine or granular materials and not materials containing a large percentage of lumps.

The Curved Blade housing is constructed of plate steel with cross member supports on larger sizes. The reinforced curved blade pivots on two flanged bearings allowing it to open and close with ease. Actuation of Curved Blade Valves can be accomplished in many ways; pneumatically for fast action, hydraulically for power, electrically for precise positioning, and manually with a chain wheel or lever.

The seals on the Curved Blade Valve are designed to eliminate product leakage when the blade is in the shut off position. The seals are mounted to the Curved Blade housing instead of the blade allowing for easy access and replacement. Blade seals are selected according to the material being handled and are available to suit any application.

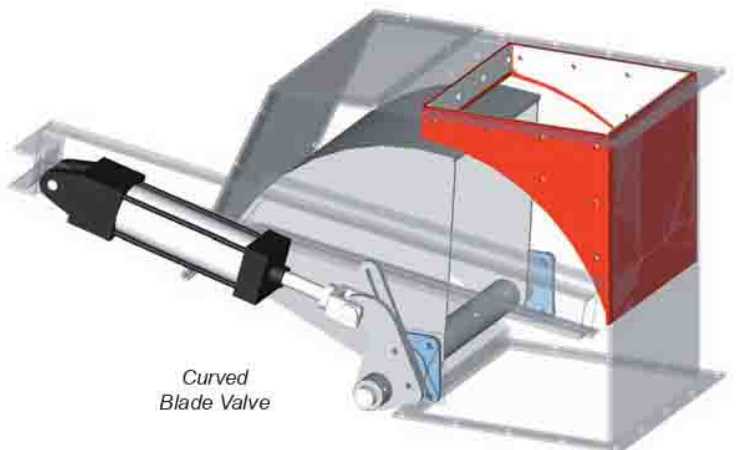

Curved
Blade Valve

08660 Ance Road
Charlevoix, Michigan 49720

Dust Control and Loading Systems Inc
www.dclinc.com or sales@dclinc.com

Tele: 800-748-0563
231-547-5600



Dust Control and Loading Systems Inc

Leaders in Innovative Bulk Loading Systems Design

Tipping Valve

TIPPING VALVE

DCL's Model Tipping Valves are designed as an airlock and to monitor product flow from outlets of dust collectors, filter modules, and other discharge points handling dry bulk materials.

Tipping Valves are very effective inexpensive airlocks. Actuation of tipping valves can be accomplished in many ways; pneumatically for fast action, electrically for precise positioning, and by gravity. The seals are designed to eliminate product leakage when the blade is in the shut off position and act as an airlock. Blade seals are selected according to the material being handled and are available to suit any application. Tipping valves can be suited to handle product at 500 degrees Fahrenheit.

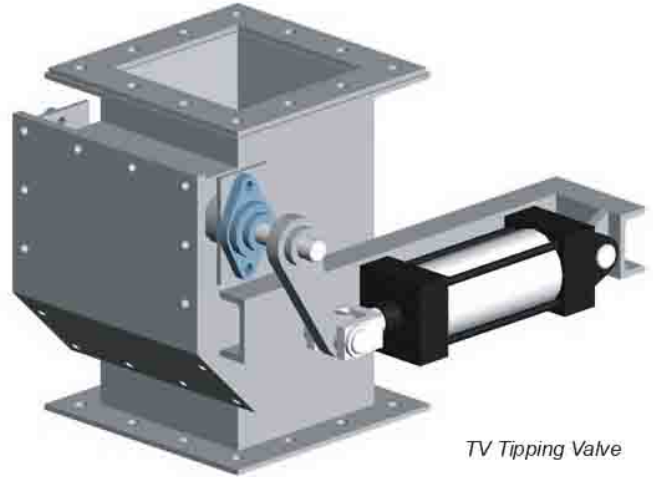

TV Tipping Valve



DTV Dual Tipping Valve

DUAL TIPPING VALVE

Dual Tipping Valves are designed as an airlock and to monitor product flow from outlets of dust collectors, filter modules, and other discharge points handling dry bulk materials.

A Dual Tipping Valve is actually two single Tipping Valves mounted together. This allows more product flow and offers an even better airlock. Dual tipping valves have a tandem actuator configuration which only requires one actuator to actuate each valve.

DCL offers a large selection of tipping valves from 6 inches [152 mm] square up to 18 inches [457 mm] square. Tipping valves are also available in sizes larger than 18 inches [457 mm] and in special configurations on a custom build basis.

A choice of construction materials allow handling of all types of products; fine, granular, abrasive, corrosive, and sanitary applications.



08660 Ance Road
Charlevoix, Michigan 49720

Dust Control and Loading Systems Inc
www.dclinc.com or sales@dclinc.com

Tele: 800-748-0563
231-547-5600



Dust Control and Loading Systems Inc

Leaders in Innovative Bulk Loading Systems Design

Flat Blade Diverter Valve

FLAT BLADE DIVERTER VALVE

DCL's Model Flat Blade Diverter Valves are designed to direct product flow from outlets of storage bins, silos, conveyors, gravity flow chutes and other discharge points handling dry bulk materials.

These rugged heavy duty flat blade diverters are available in offset, symmetrical, and triverter configurations. Standard sizes range from 6 inches to 36 inches square. Sizes larger than 36 inches, rectangular, and special configurations including hardened liners are available on a custom build basis.

A choice of construction materials allow handling of all types of products; fine, granular, lumpy, abrasive, corrosive, and sanitary applications.



Flat Blade Offset Diverter



FEATURES

The housing is constructed of plate steel with cross member supports on larger sizes. The reinforced blade pivots on two flanged bearings allowing it to open and close with ease. Actuation of Flat Blade Diverter Valves can be accomplished in many ways; pneumatically for fast action, hydraulically for power, electrically for convenience, and manually with a chain wheel or lever.

The seals on the Flat Blade Diverter are designed to eliminate product leakage when the blade is in the diverted position. The seals are located at the top, sides, and bottom of the blade. Blade seals are selected according to the material being handled and are available to suit any application.

MODELS AVAILABLE

The Flat Blade Offset Diverter Valve is configured to direct the product flow straight through or to one side of the diverter. Typical product outlet offsets are 30 or 45 degrees off center. One blade and actuator is used on this diverter valve.

Flat Blade Symmetrical Diverter Valves have two product outlets, each 30 or 45 degrees off center. One blade and actuator is used on this diverter valve.

The Flat Blade Triverter Valve has one inlet and three outlets. The two side product outlets are 30 or 45 degrees off the center outlet. Two blades and actuators are used on this valve.

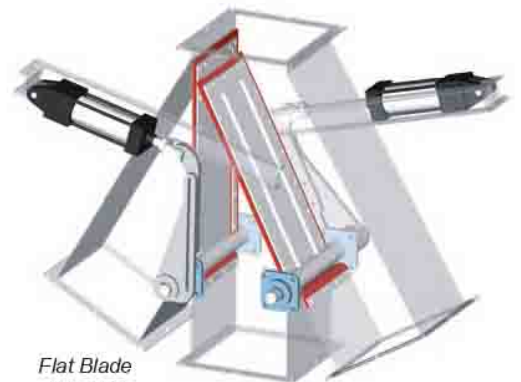

Flat Blade Triverter

08660 Ance Road
Charlevoix, Michigan 49720

Dust Control and Loading Systems Inc
www.dclinc.com or sales@dclinc.com

Tele: 800-748-0563
231-547-5600



Dust Control and Loading Systems Inc

Leaders in Innovative Bulk Loading Systems Design

Curved Blade Diverter Valve

CURVED BLADE DIVERTER VALVE

DCL's Model Curved Blade Diverter Valves are designed to direct and cut off product flow from outlets of storage bins, silos, conveyors, gravity flow chutes and other discharge points handling dry bulk materials.

These rugged heavy duty curved blade diverters are available in 30 and 45 degree symmetrical configurations. Standard sizes range from 6 inches to 36 inches square. Sizes larger than 36 inches, rectangular, and special configurations including hardened liners are available on a custom build basis.

A choice of construction materials allow handling of all types of products; fine, granular, abrasive, corrosive, and sanitary applications.

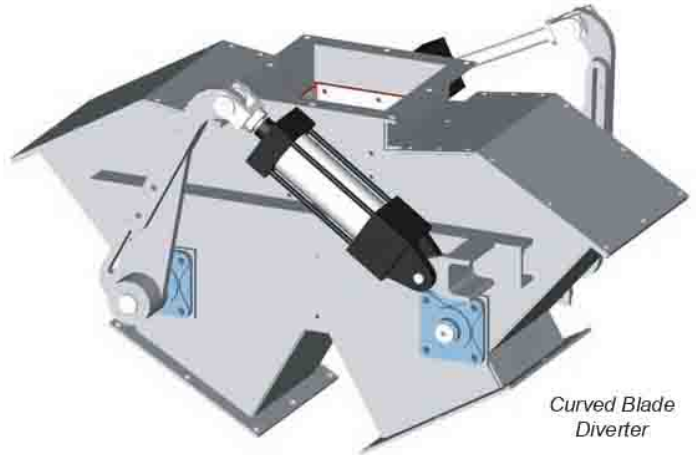

Curved Blade Diverter



FEATURES

The Curved Blade Diverter Valves are fast acting, tight sealing, and very effective for regulating flow rates. The diverter configuration will allow not only a selection of flow to one or both legs at the same time, but will also act as a complete shut off valve. The curved blade valve should only be used when handling fine or granular materials and not materials containing a large percentage of lumps.

The CBD housing is constructed of plate steel with cross member supports on larger sizes. Each reinforced curved blade pivots on two flanged bearings allowing it to open and close with ease. Actuation of Curved Blade Diverter Valves can be accomplished in many ways; pneumatically for fast action, hydraulically for power, electrically for precise positioning, and manually with a chain wheel or lever.

The seals on the Curved Blade Diverter are designed to eliminate product leakage when the blade is in the shut off position. The seals are mounted to the housing instead of the blade allowing for easy access and replacement. Blade seals are selected according to the material being handled and are available to suit any application.

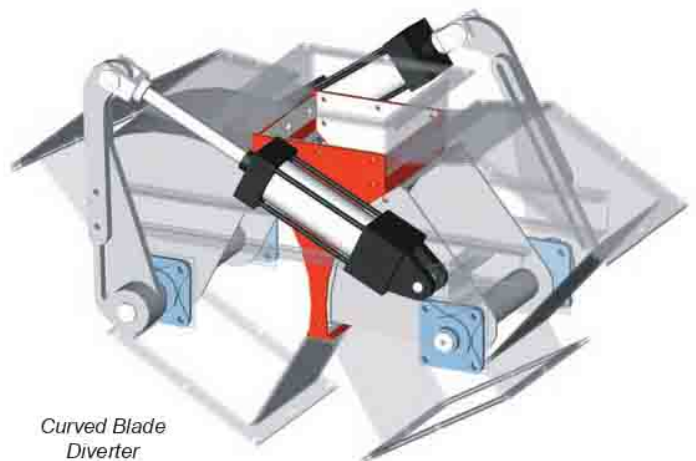

Curved Blade Diverter

08660 Ance Road
Charlevoix, Michigan 49720

Dust Control and Loading Systems Inc
www.dclinc.com or sales@dclinc.com

Tele: 800-748-0563
231-547-5600